



# ASCENT WAKEBOARD TOWER

## INSTALLATION GUIDE



---

### INSTALLATION SUPPORT

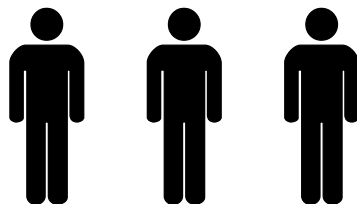



## IMPORTANT INFORMATION

---

- The Aerial Assent tower fits motor boats with 67-96 inch wide beam widths. *This measurement is taken from the Port to Starboard mounting points.*
- Do not fold the tower without having the top section securely fastened to the side sections with the fasteners provided.
- Lubricate the telescopic side section tubes that slide in and out of the top section during installation. We recommend using a light grease to help the tubes slide together without binding.
- Do not fold the tower by yourself.
- Do not assemble tower on the ground and then try to install it on the boat.
- Do not use impact drivers to install any hardware.
- We recommend using threadlocker on the threads of all fasteners that will not be adjusted while lowering or raising the tower.
- Check the top section for burrs before installing side sections to prevent the scratching and marking of tubes. *Aerial does not cover damage caused by burrs during installation.*
- If the area of the deck where the tower will be mounted has a fiberglass thickness of less than 1/4 inch, a backing plate kit must be purchased and installed to provide adequate support.
- Please leave the foam wrap on the tower until the installing is complete.
- Please note that when towing your boat you may notice what appears to be movement in your tower. It is important to understand that the boat is also moving on the trailer and that this movement can be visually deceiving.

## CLEANING

---

- Frequently wash your tower with soap and water.
- As required, use Mothers Mag & Aluminum polish to restore your tower to its original finish.

## WARNING

---

- **BE CAREFUL** when assembling this product. We **CANNOT** be liable for any burring or scratching that may occur when sliding sections in and out of each other.
- **NEVER** modify this product in any way.
- **NEVER** climb, stand or ride on this product.
- **NEVER** tow watersport tubes or inflatable's with this or any other Aerial Wakeboard Tower.
- **ALWAYS** use caution with approaching bridges or overpasses.
- **ALWAYS** inspect this product for loose bolts, fittings or damage before each use.
- Always carefully **CONSULT** the user manual for proper installation, maintenance and usage.
- **AERIAL WAKEBOARDING** is not liable for personal injury or property damage from the use of this or any other Aerial product.



## TOWER EXPLODED VIEW

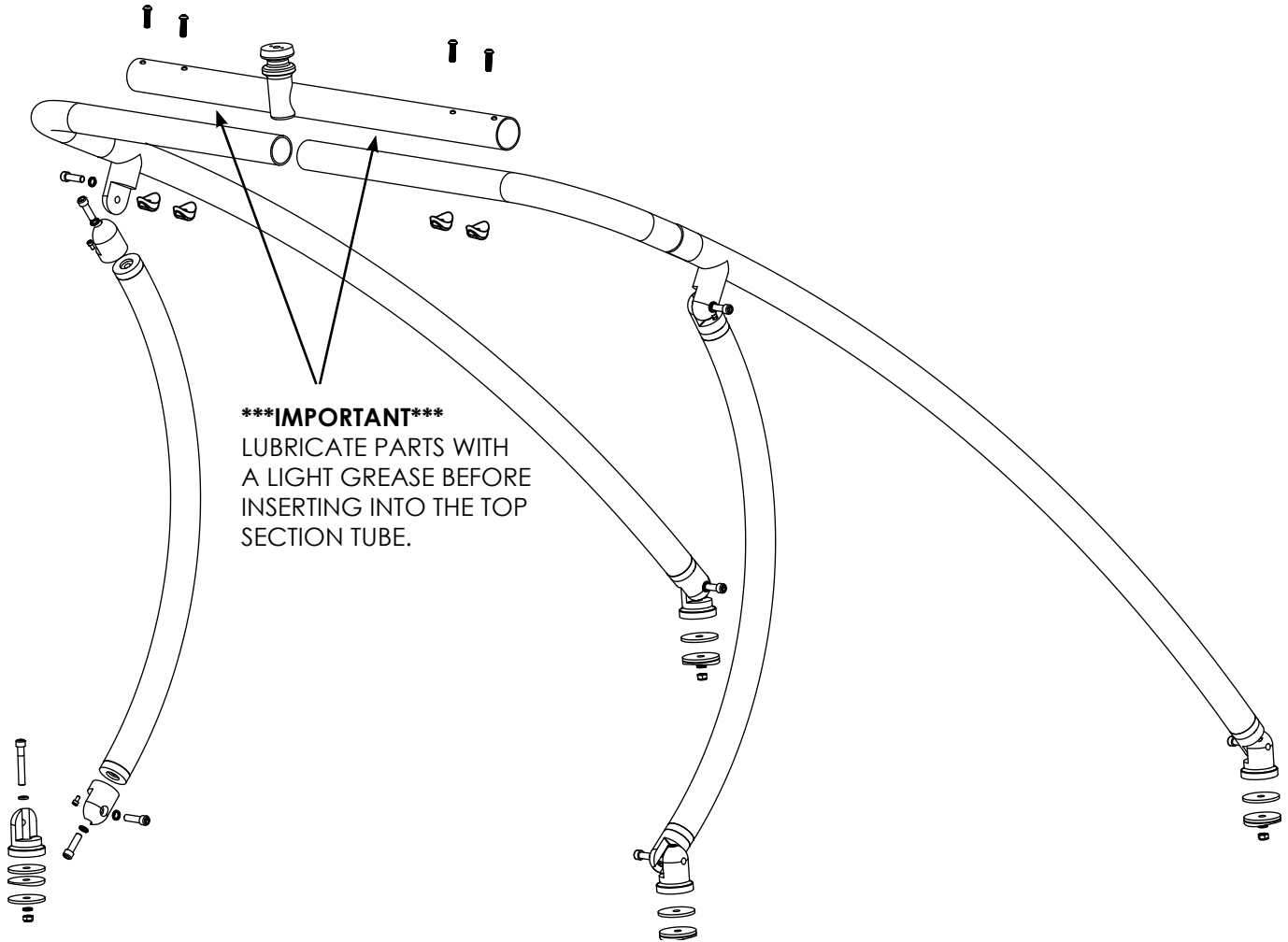

---

## TOOLS REQUIRED





## PARTS LIST

### TOWER PACKAGE

ITEM #	DESCRIPTION	QTY	COMMENTS
1	2.25" TOWER JOINT - THREADED (INCL. M6 X 12mm BOLT)	2	
2	2.25" TOWER JOINT - THRU HOLE (INCL. M6 X 12mm BOLT)	4	
3	DECK MOUNT	4	
4	M12 X 40mm BOLT	8	FOR USE WITH ITEMS - 1, 2
5	M12 X 45mm BOLT	4	FOR USE WITH ITEMS - 3
6	M12 X & 75mm BOLT	4	FOR USE WITH ITEMS - 3
7	M12 SPRING LOCK WASHER	16	FOR USE WITH ITEMS - 4, 5, 6
8	M10 X 75mm BUTTON HEAD BOLT	4	FOR USE WITH ITEMS - 19
9	M10 LOGO NUT	4	FOR USE WITH ITEMS - 19
10	M12 NYLON LOCK NUT	4	FOR USE WITH ITEMS - 6
11	M12 FLAT WASHER	4	FOR USE WITH ITEMS - 6
12	LARGE NYLON FLAT WASHER (OD = 70mm)	4	FOR USE WITH ITEMS - 3
13	CURVED RUBBER WASHER (OD = 70mm)	4	FOR USE WITH ITEMS - 3
14	LARGE ALUMINUM FLAT WASHER (OD = 70mm)	4	FOR USE WITH ITEMS - 3
15	M12 ALLEN KEY	1	
16	M8 ALLEN KEY	1	
17	M6 ALLEN KEY	1	
18	THREADLOCKER	1	
19	TOP SECTION TUBE	1	
20	REAR LEGS	2	
21	FRONT LEGS	2	1 PORT & 1 STARBOARD



## STEP 1

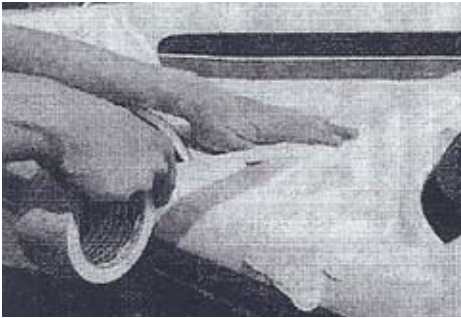

With masking tape, cover the area where the mounting brackets will be placed. This should be done at all points where the tower will make contact with the deck as well as the surrounding area. This will help to eliminate scratches to your boat while adjusting and measuring your tower attachment points.

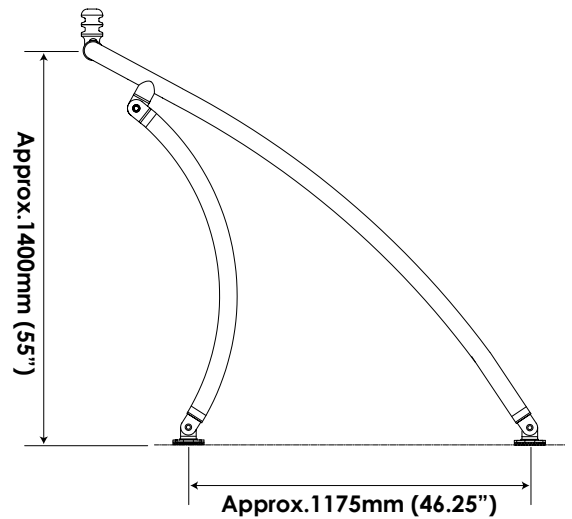

## STEP 2

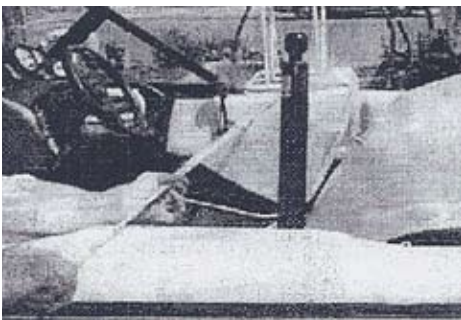

With your tape measure, measure the distance across the beam of your boat where the rear mounts will be fixed and write down the measurement numbers. Next, measure up from the rear mounts to the front mounting locations and mark a general location on the masking tape where the mount will sit.

## STEP 3

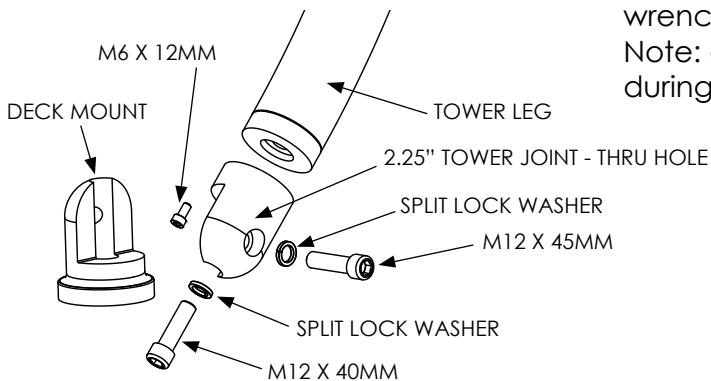

Attach the tower fittings and mounting feet to the tower legs using the bolts provided and lightly secure these with an Allen wrench.

Note: do not over tighten these as you need to adjust them during the following installation steps.



## STEP 4



Using the front mount width (measured in Step 2), connect the 2 front tower legs to the top section tube by inserting the upper straight tube sections of the front legs inside the top section tube. Make sure you do not over insert the front leg telescopic tubes during this process as the top section tube will mark and scratch the smaller front leg tube. It is also important to keep the top section centered during the process.

### \*\*\* IMPORTANT NOTES \*\*\*

- Lubricate telescopic parts with a light grease before sliding together.
- Grease will not prevent the smaller diameter tube from being scratched by the top section tube during insertion so be very careful not insert the side section tube any further than the final installation width.

**Note: Both SIDE and TOP mounts are possible. Be sure to compensate for the additional width of approx. 3" required for a side mount.**

## STEP 5



Bring the assembled portion of the tower up and over the front mounting area and position the mounts over the marks that you made in step 2.

Confirm that the mounting locations for both the front and rear deck mounts are suitable.

We recommend tracing around the deck mount to mark its exact location on the deck.

Once the deck mounts have been traced, remove the tower and mark the drill locations using the central hole in the large nylon washer as a template.

**Note: During this step it is also important to confirm that the top section width is correct.**

## STEP 6



After confirming (double check) that your top section width measurements are correct, remove the tower from the boat and secure all three tubes together while ensuring that the tow point is correctly aligned vertically as well as being centered on the tower.

To do this you will need to drill (using a 27/64" drill bit) 4 holes through the two front leg tubes, making sure they are aligned with the pre-drilled holes in the top section. Then take the 4 supplied M10 x 75mm bolts and M10 Logo nuts, and fasten the three tower tube sections together.

NOTE: The tow point should also be positioned on the rear of the top section tube so that the logo plate is facing towards the bow of the boat.



## STEP 7



Once you have marked your deck mount drilling locations it is very important that you check the underside of the deck for wires. If necessary, you should move the wires out of the way in preparation for drilling.

## STEP 8

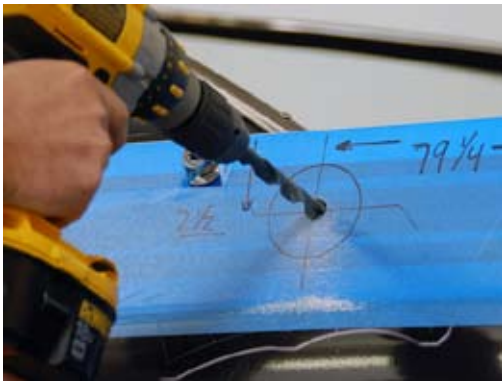

It is now time to drill the mounting holes in the deck of your boat for the front deck mounts.

We recommend first drilling a small pilot hole which will keep the 17/32" drill bit from walking (moving). A countersinking bit or a small rat tail file can be used to ease the edge and keep the gel coat from chipping.

## DRILLING PROCEDURE

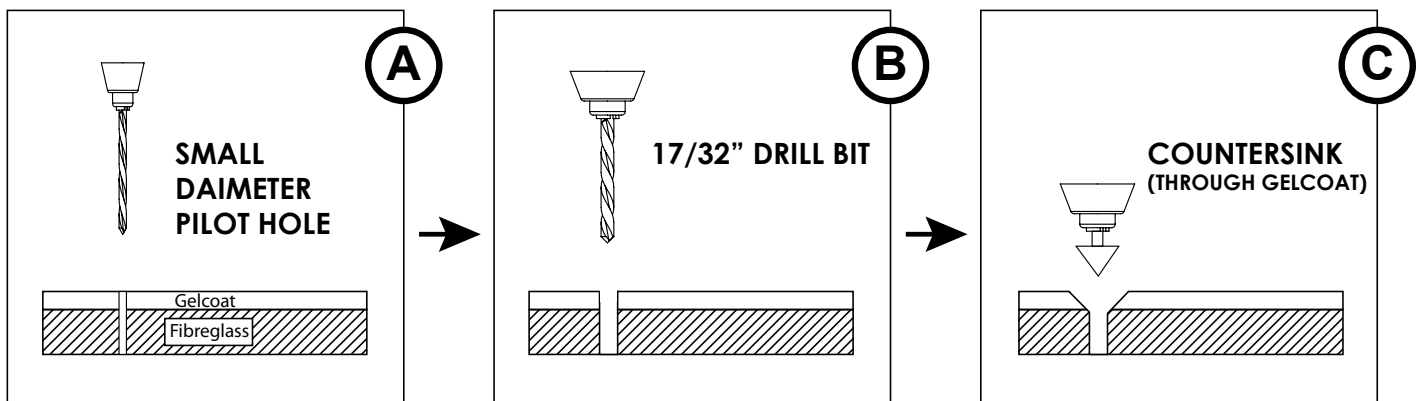



## STEP 9

Install the tower mounts to the boat deck in the order shown in the diagram.

**Note: in the case where the deck of your boat is less than 1/4" thick, a reinforcing kit is required to thicken and reinforce the deck in the mounting locations.**

### FLAT DECK - MOUNT ASSEMBLY

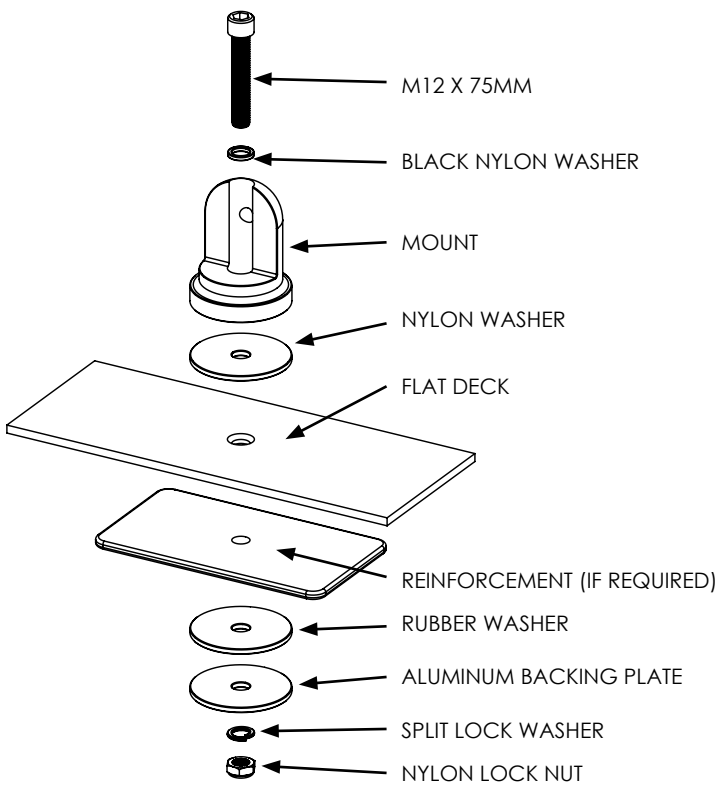

### CURVED DECK - MOUNT ASSEMBLY

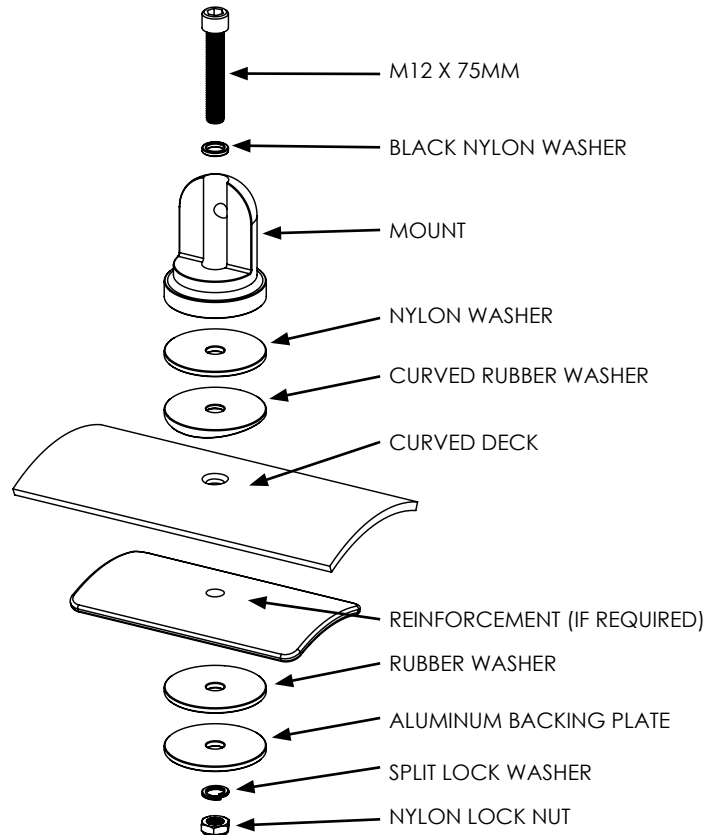

Once the mount and its parts are assembled they can then be secured in position with a wrench.

### **\*\*\*IMPORTANT NOTE\*\*\***

**When folding the tower the aluminum mounts will rotate on the surface of the nylon washer. When fastening the mount to the boat deck, ensure that the mount is securely tightened in position but not overly tight that it will prevent the mount from rotating.**





## STEP 10

Attach the rear tower legs to the front tower legs with the mounting fittings and fasteners supplied. All mounts are designed to swivel to ensure a square and even installation. Once all the fittings are correctly aligned they must then be firmly secured in position with an Allen wrench. We recommend using threadlocker during the installation of these fasteners - **only on fasteners that will not require loosening in order to fold the tower.**

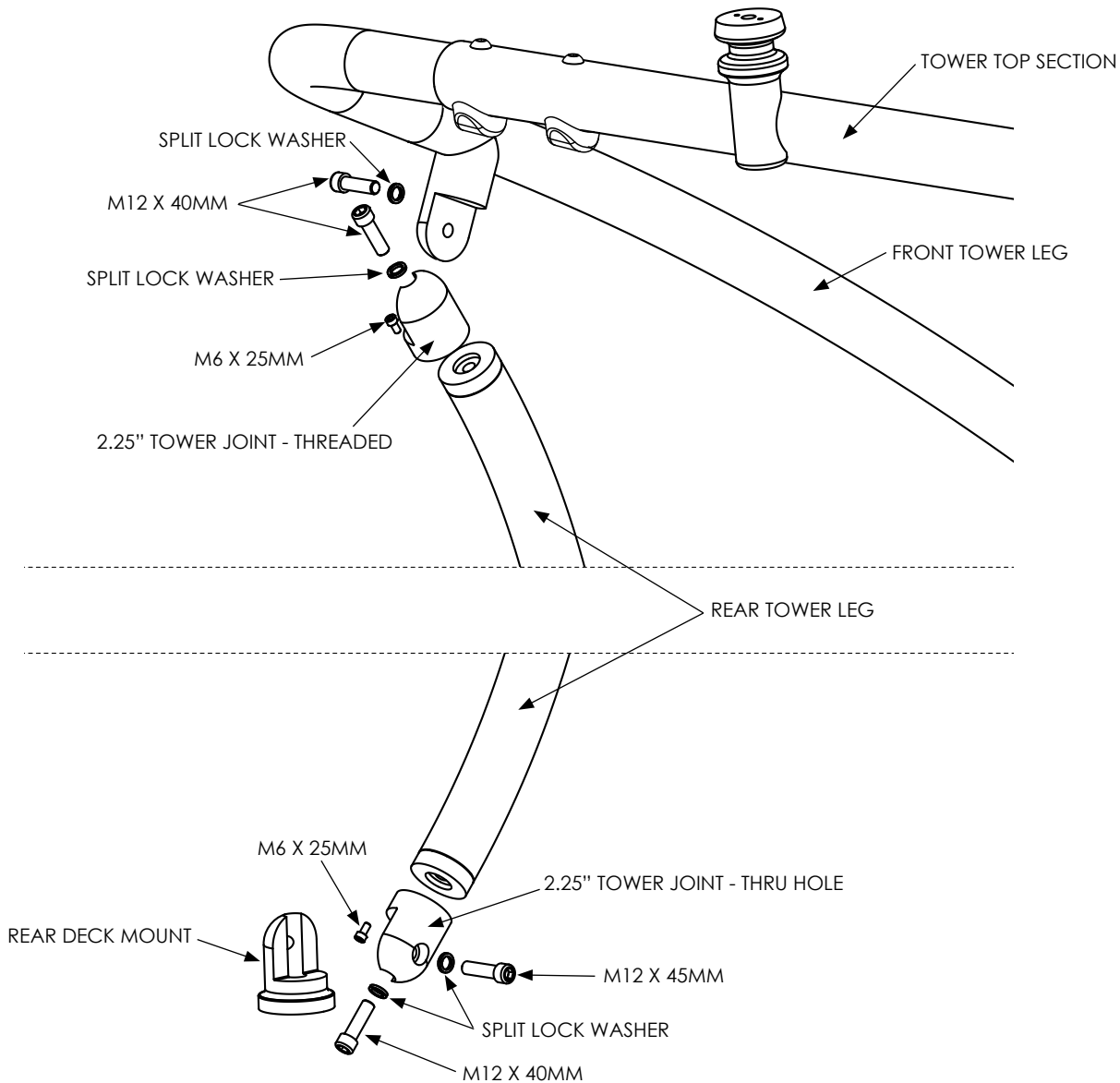

## STEP 11 - MARKING, DRILLING AND INSTALLING THE REAR DECK MOUNTS

Follow steps 5, 7, 8 & 9 for marking, drilling and installing the rear deck mounts.



## STEP 12 - LOCKING THE ROTATING FITTINGS

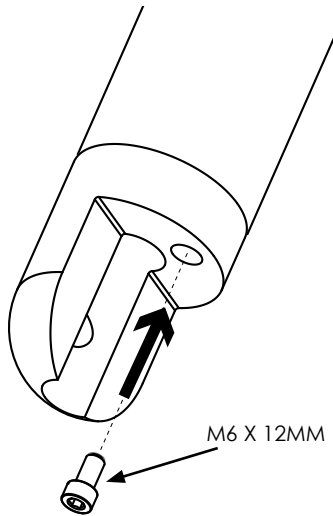

Once you are happy with your tower installation and all of the fittings are lined up to allow the tower to fold and function correctly it will then be important to firmly lock the rotating fittings in place to prevent any unwanted rotation or loosening. To do this the pre-installed M6 x 12mm fasteners found in the fittings will need to be firmly tightened with an Allen key. We recommend using threadlocker during this step.

## STEP 13 - FOLDING THE TOWER

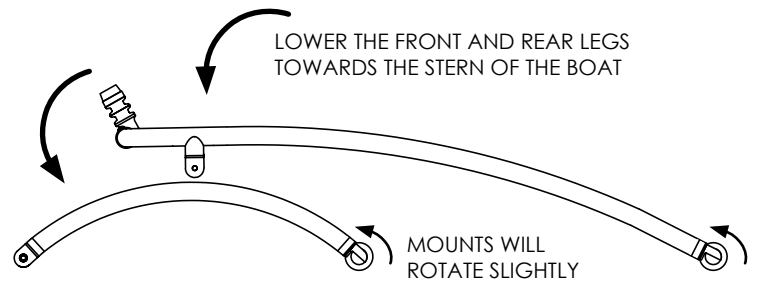
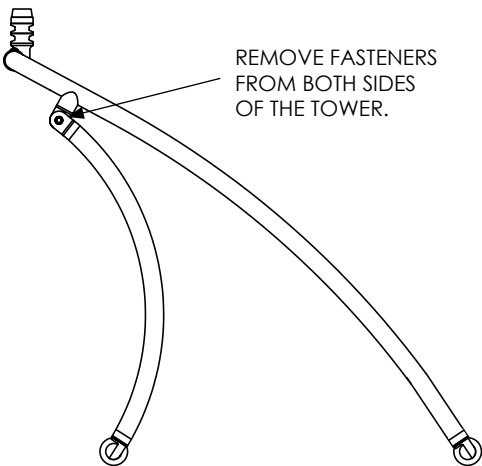

To fold the tower we recommend removing the 2 fasteners that connect the top of each rear leg to the front legs. This will allow you to fold the rear legs back (or remove them) and allow the front legs to fold back and rest on the deck of the boat. The fasteners that connect the legs to the mounts may also require loosening before folding the tower.

When folding the tower down you will notice that the tower mounts will rotate on the nylon washers located under the mount on the surface of the deck.

**Before using the tower again, be sure to check and tighten all the fasteners that may have been loosened or removed during the folding process.**



## INSTALLING THE NAVIGATION LIGHT

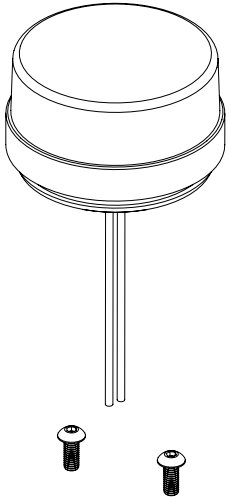

The navigation light is shipped separately. It is designed to be installed on the top of the tow point. For a clean wiring installation the wires supplied can be passed through the center of the tow point, along the inside of the top-section and down inside the front leg tube. The wires will need to exit the leg tube just above the mounting foot fittings and then enter the deck of the boat (through a hole that will need to be drilled) so that they can be connected to a switch and power source.

*Note: The tower is not supplied with pre-drilled wiring holes as each customer may have a different wiring requirement depending on how they fold their tower or the accessories that they will mount to the tower.*

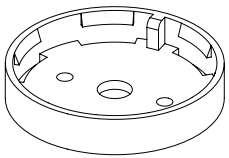

NAVIGATION LIGHT  
(SHIPPED SEPARATELY)



[www.aerialwakeboarding.com](http://www.aerialwakeboarding.com)